

Specifications

Nominal Voltage		12 V
Capacity (25°C)	20HR(10.5V)	7Ah
	10HR(10.5V)	6.6Ah
	1HR(9.60V)	4.58Ah
Dimension	Length	151 ± 1.5mm (5.94inch)
	Width	65 ± 1mm (2.56inch)
	Height	94 ± 1mm (3.70inch)
	Total Height	100 ± 1mm (3.94inch)
Approx. Weight		2.15kg (4.74lbs) ± 5%
Terminal type		T1/T2
Internal resistance (Fully charged, 25°C)		Approx. 28m Ω
Capacity affected by temperature (20HR)	40°C	102%
	25°C	100%
	0°C	85%
	-15°C	65%
Self-discharge (25°C)	3 month	Remaining Capacity: 91%
	6 month	Remaining Capacity: 82%
	12 month	Remaining Capacity: 65%
Nominal operating temperature		25°C ± 3°C (77°F ± 5°F)
Operating temperature range	Discharge	-15°C ~ 50°C (5°F ~ 122°F)
	Charge	-10°C ~ 50°C (14°F ~ 122°F)
	Storage	-20°C ~ 50°C (-4°F ~ 122°F)
Float charging voltage(25°C)		13.60 to 13.80V Temperature compensation: -18mV/°C
Cyclic charging voltage(25°C)		14.50 to 14.90V Temperature compensation: -30mV/°C
Maximum charging current		2.1A
Terminal material		Copper
Maximum discharge current		105A(5 sec.)
Designed floating life(20°C)		10years

- ◆ Absorbent glass mat technology;
- ◆ Recognized by UL & CE;
- ◆ ABS container.

Constant Current Discharge Characteristics (A, 25°C)

F.V/TIME	5min	10min	15min	30min	60min	2h	3h	4h	5h	10h	20h
9.60V	26.8	16.9	13.4	7.47	4.58	2.50	1.80	1.44	1.22	0.67	0.36
9.90V	26.0	16.4	13.1	7.32	4.51	2.49	1.79	1.43	1.22	0.66	0.36
10.2V	24.9	15.7	12.6	7.10	4.40	2.47	1.77	1.42	1.21	0.66	0.35
10.5V	23.8	15.1	12.2	6.93	4.31	2.43	1.76	1.41	1.20	0.66	0.35
10.8V	22.5	14.2	11.5	6.67	4.18	2.37	1.71	1.37	1.16	0.64	0.35

Constant Power Discharge Characteristics (Watt, 25°C)

F.V/TIME	5min	10min	15min	30min	60min	2h	3h	4h	5h	10h	20h
9.60V	299	191	153	85.6	53.1	29.3	21.4	17.1	14.6	7.99	4.29
9.90V	290	185	149	83.9	52.3	29.1	21.2	17.0	14.5	7.95	4.28
10.2V	278	177	144	81.4	50.9	28.9	21.1	16.9	14.4	7.92	4.26
10.5V	266	170	139	79.4	49.9	28.4	20.9	16.8	14.3	7.87	4.23
10.8V	251	160	131	76.5	48.4	27.7	20.3	16.3	13.9	7.71	4.15

Note: The above characteristics data can be obtained within three charge/discharge cycles.

MM1207(12V7Ah)



Dimensions

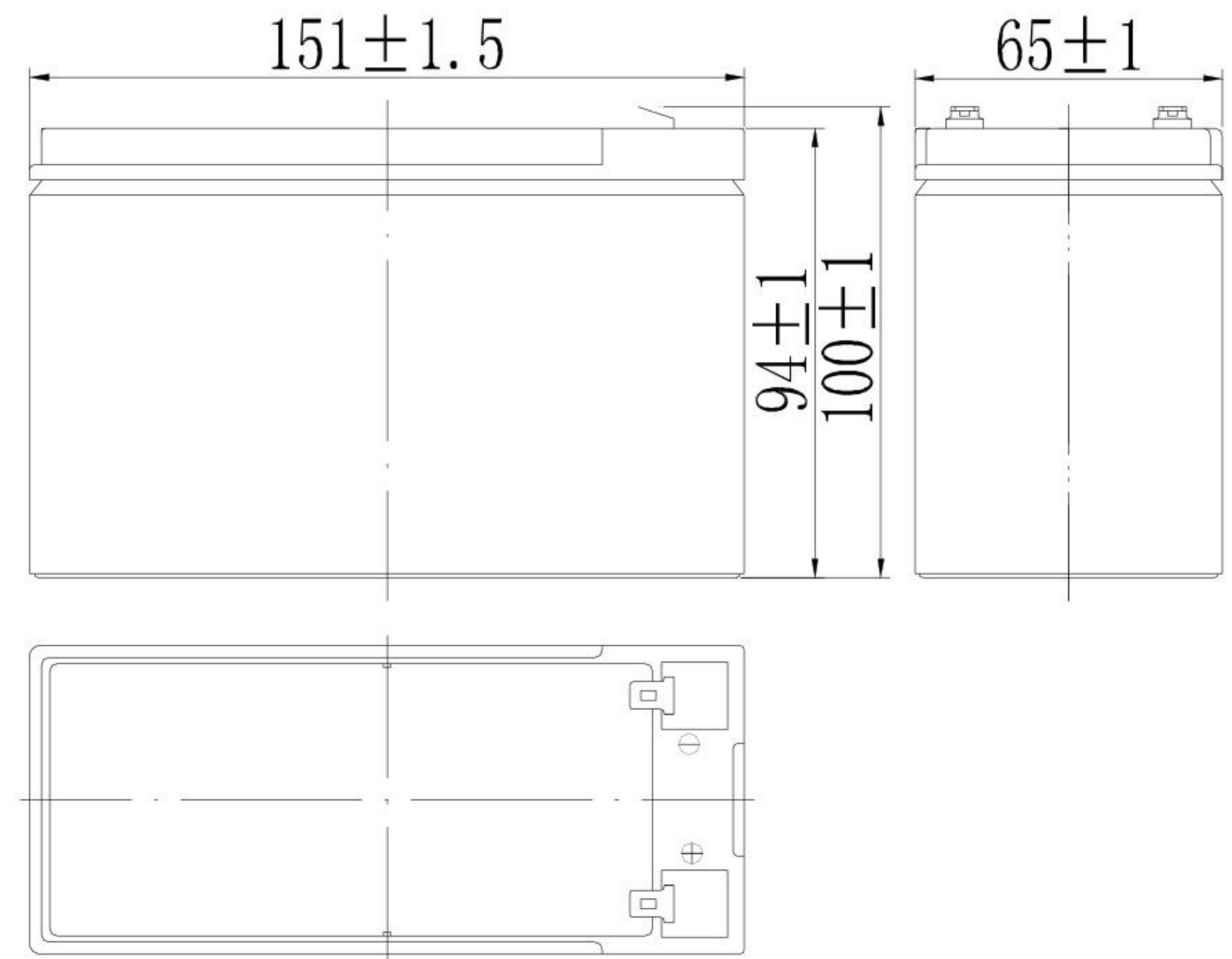

Terminal

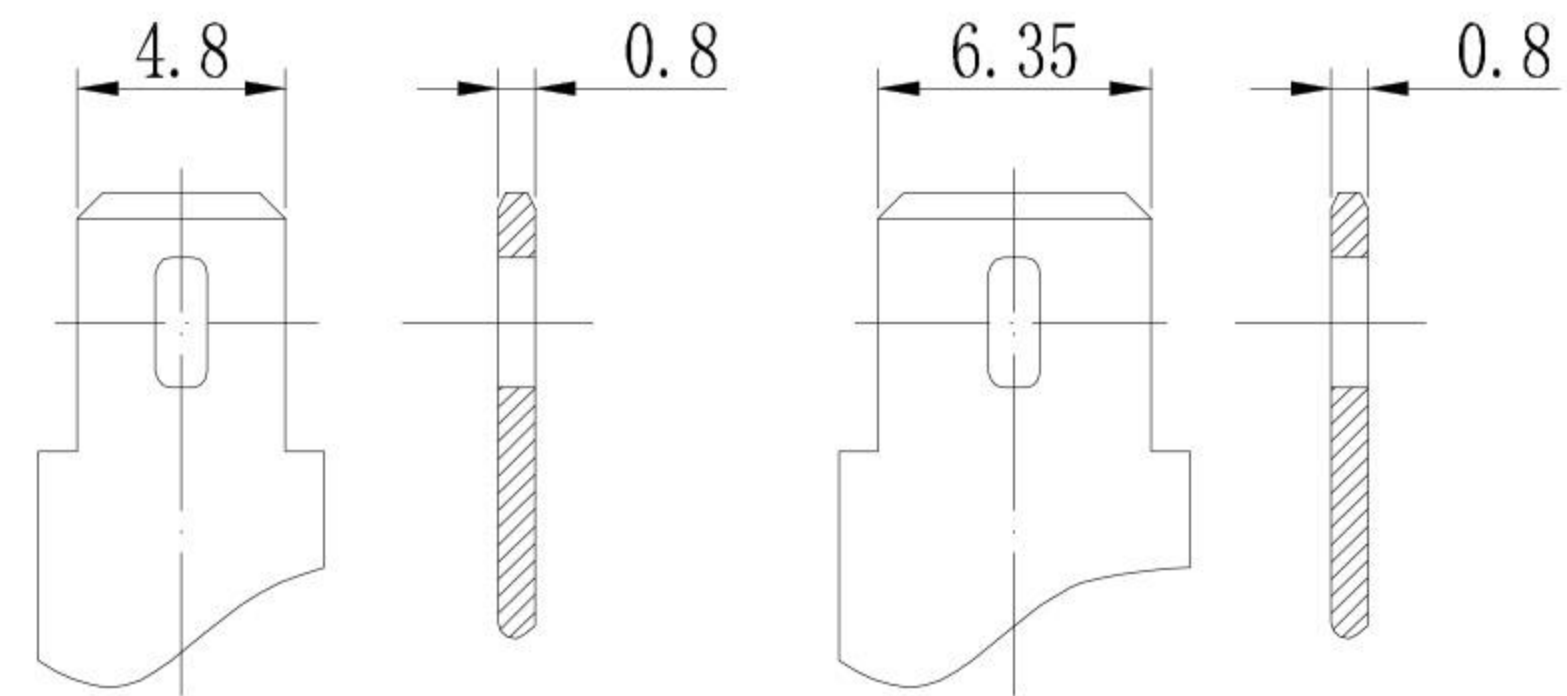

Terminal T1

Terminal T2

Discharge Characteristics(25°C)

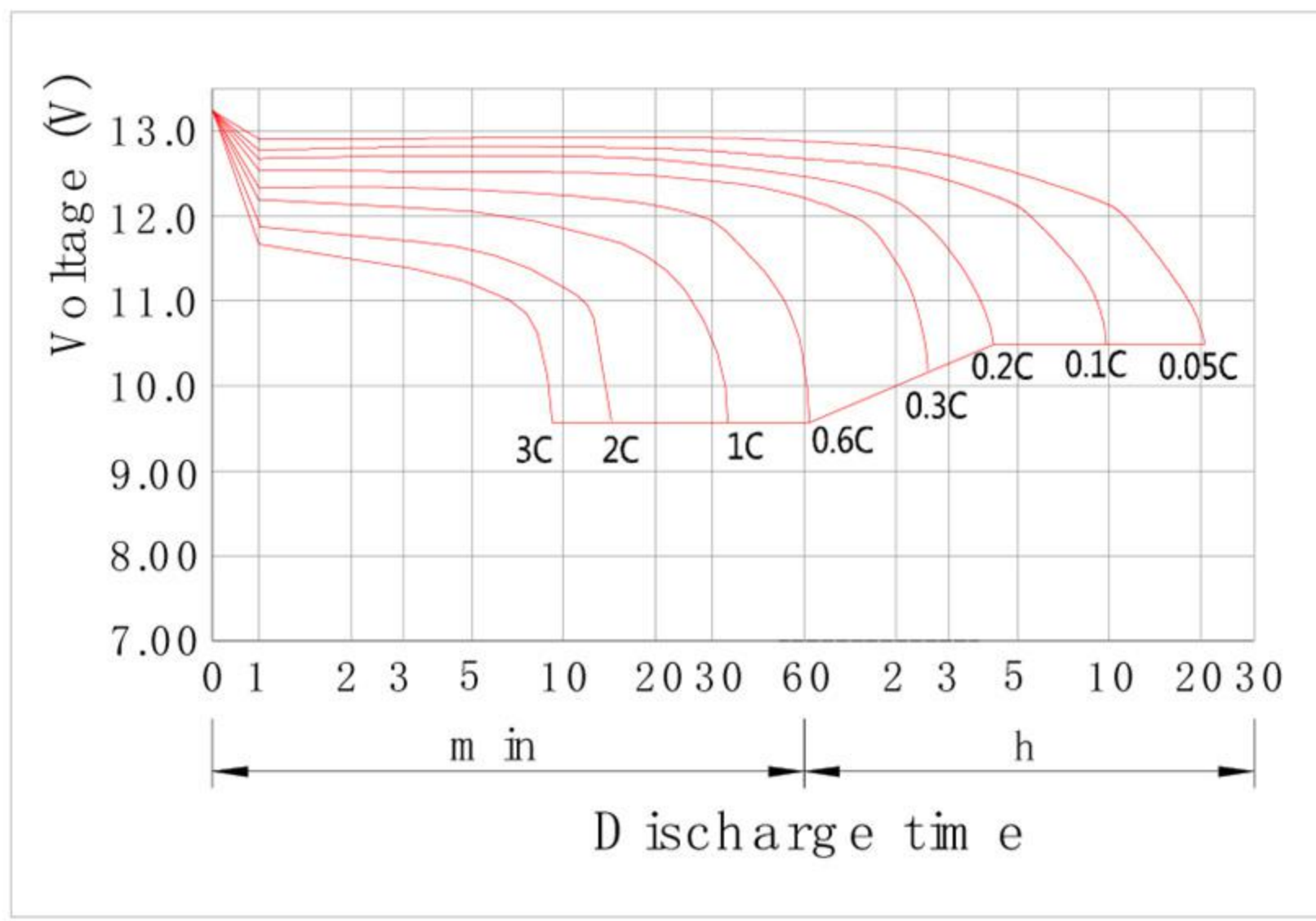

Charging Characteristics(25°C)

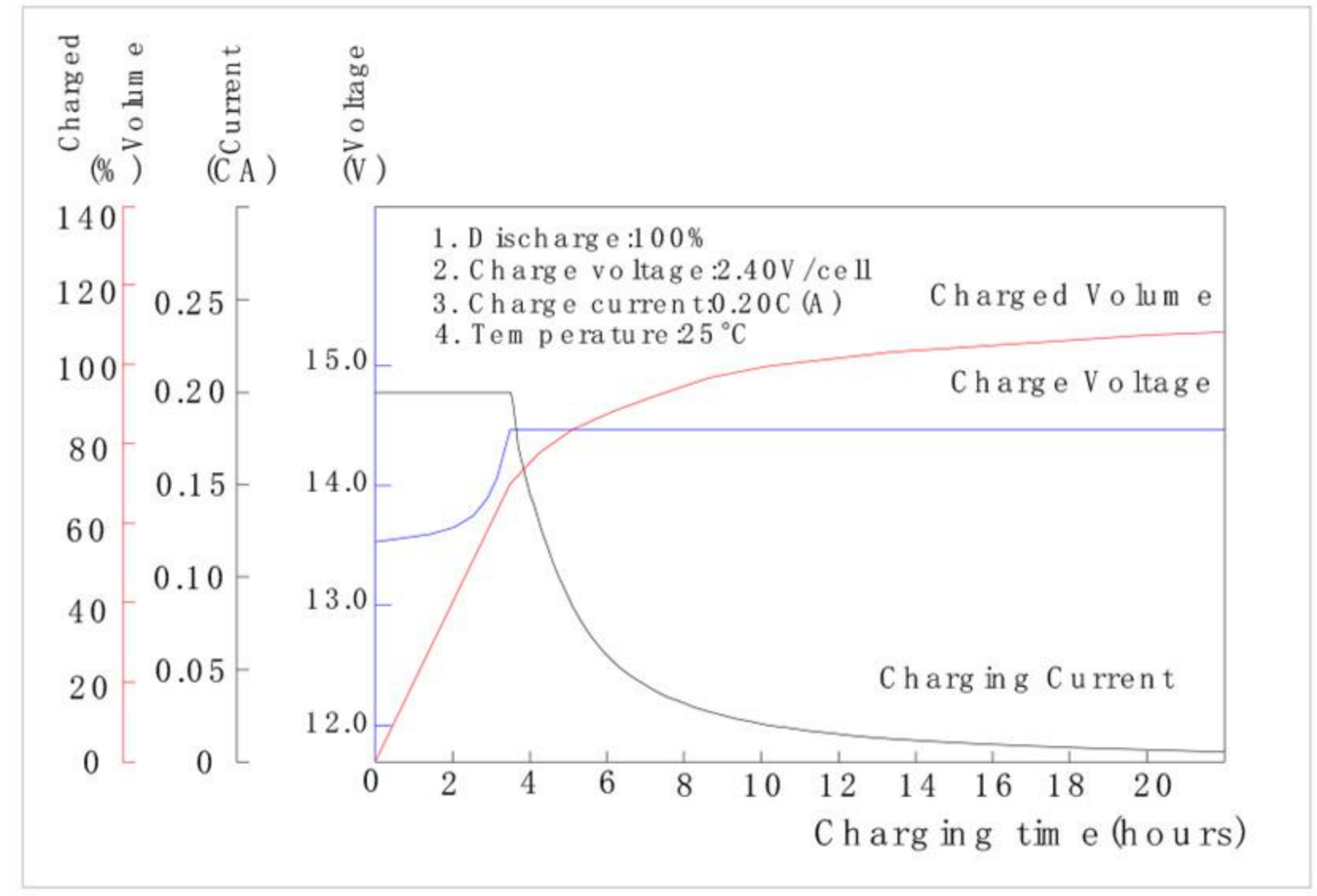

Effect of Temperature on Capacity

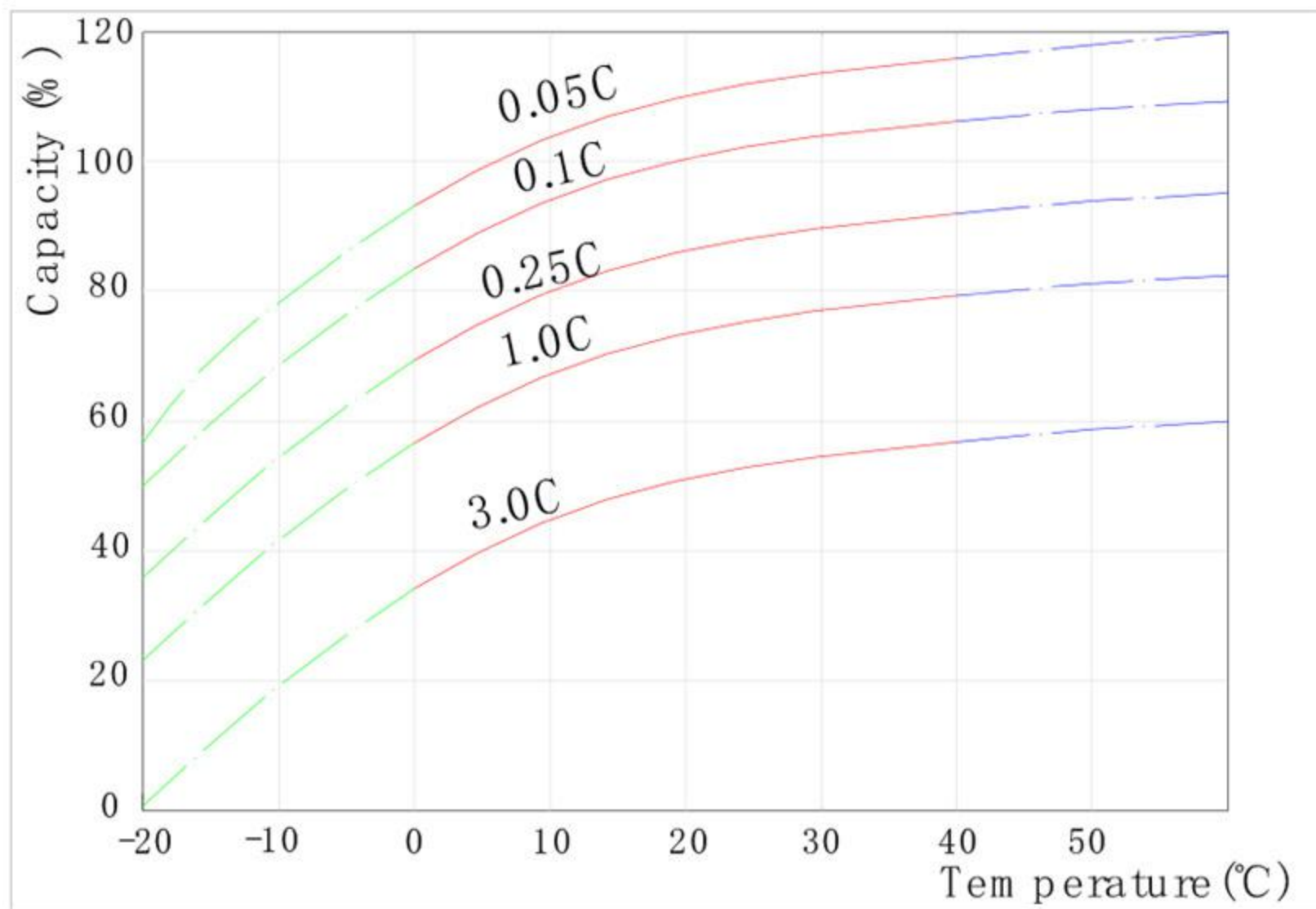

Self-discharge Characteristics

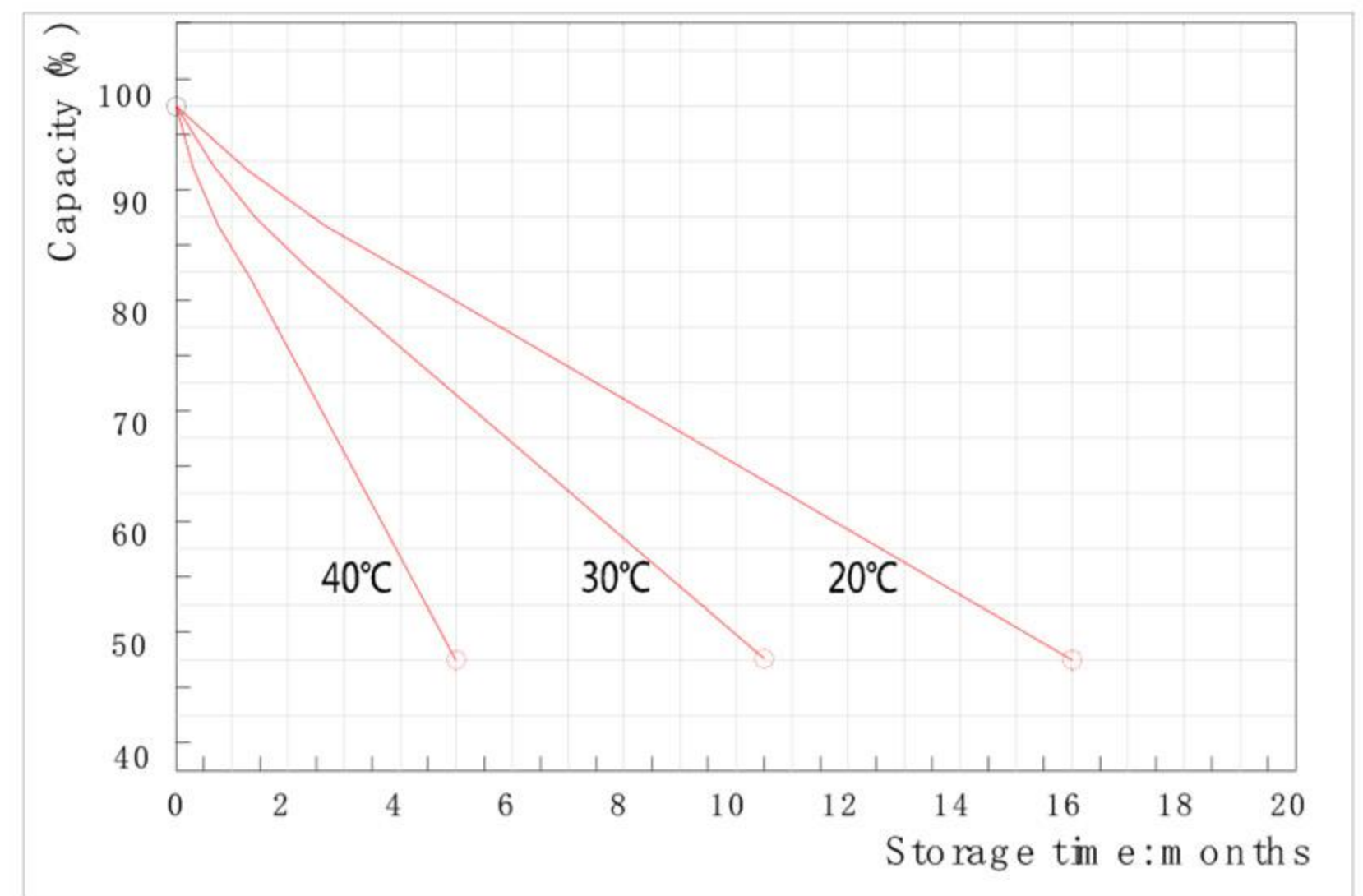

The Relationship for Open Circuit Voltage and Residual Capacity (25°C)

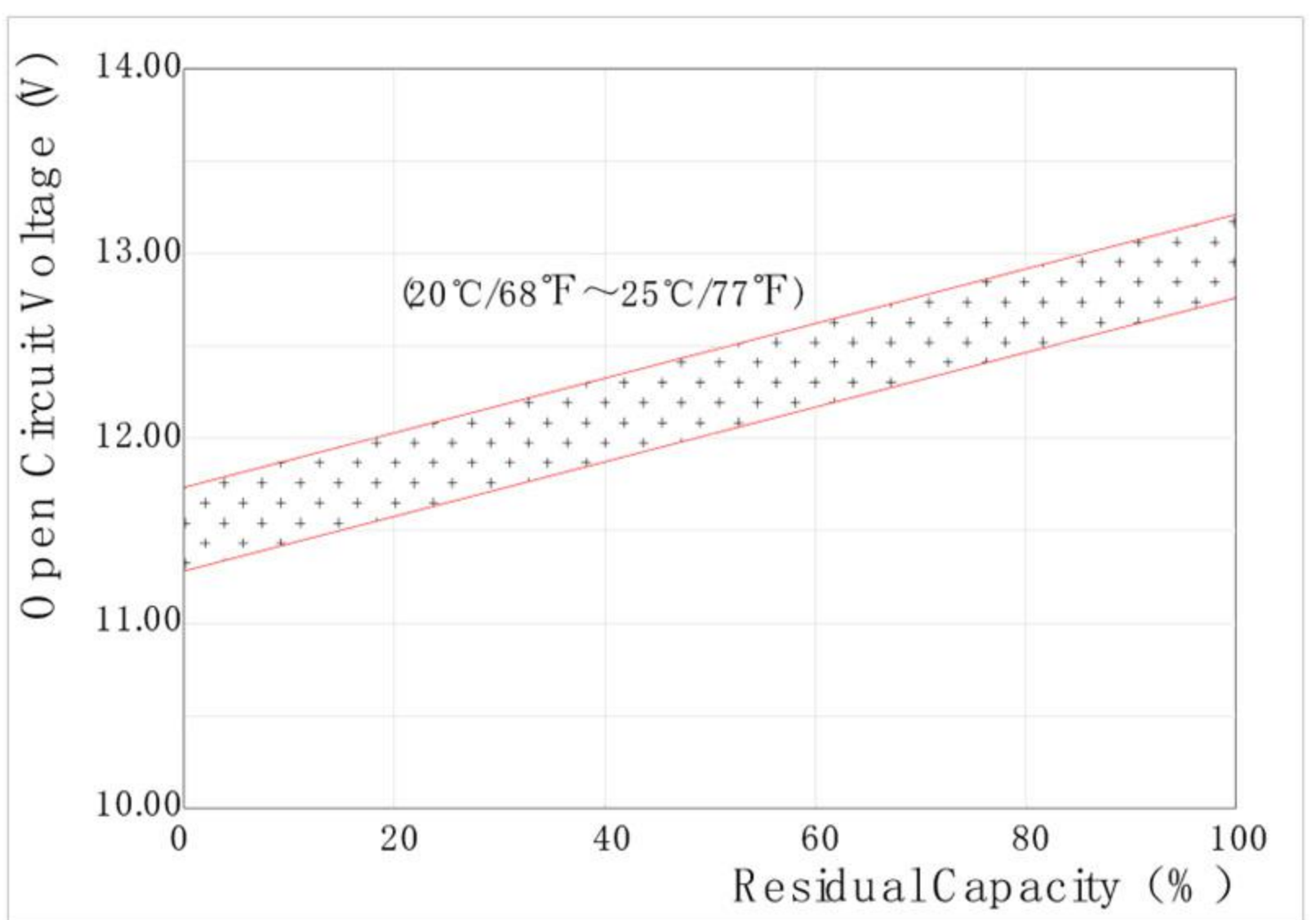

The Relationship for Charging Voltage and Temperature

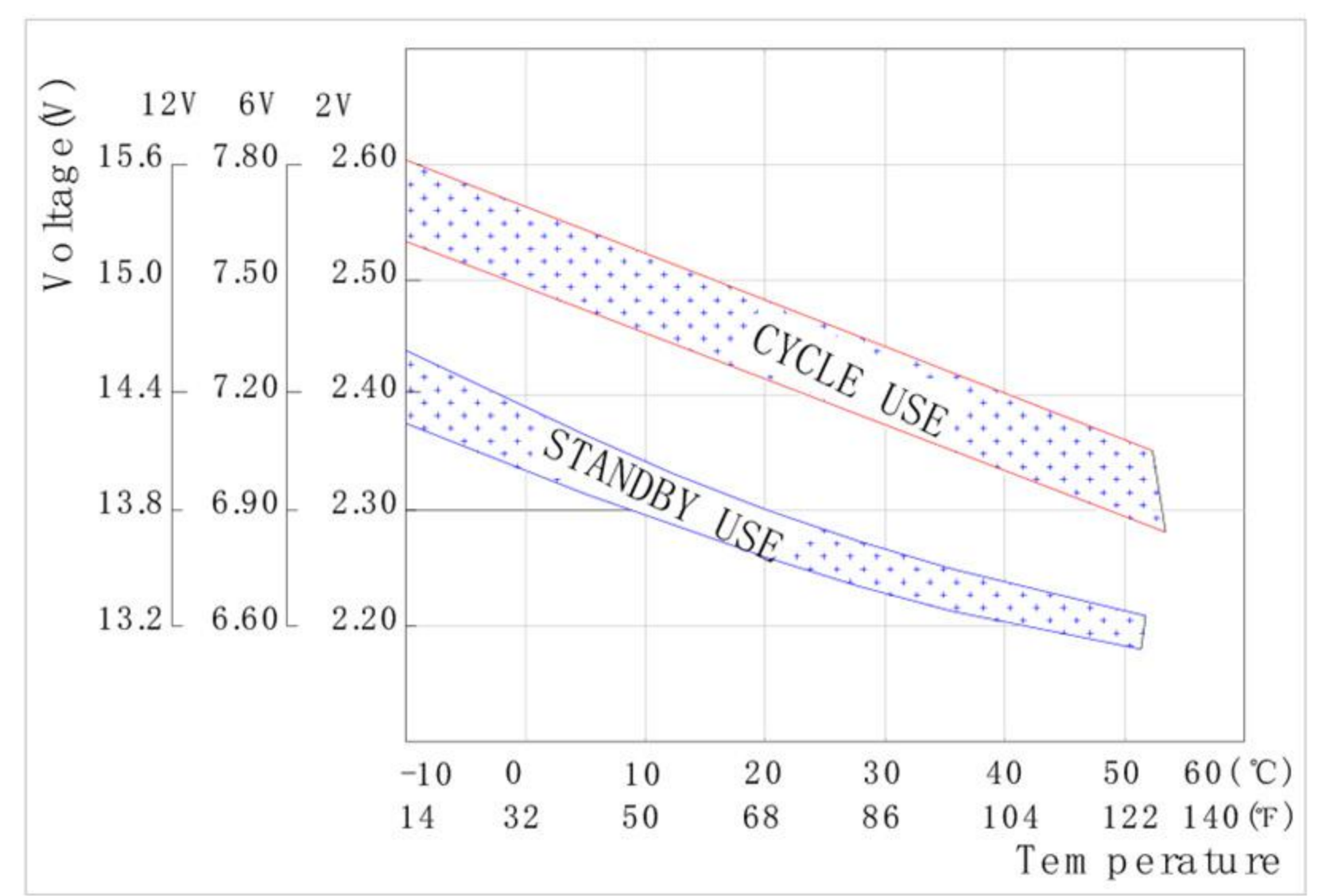

Floating Life on Temperature

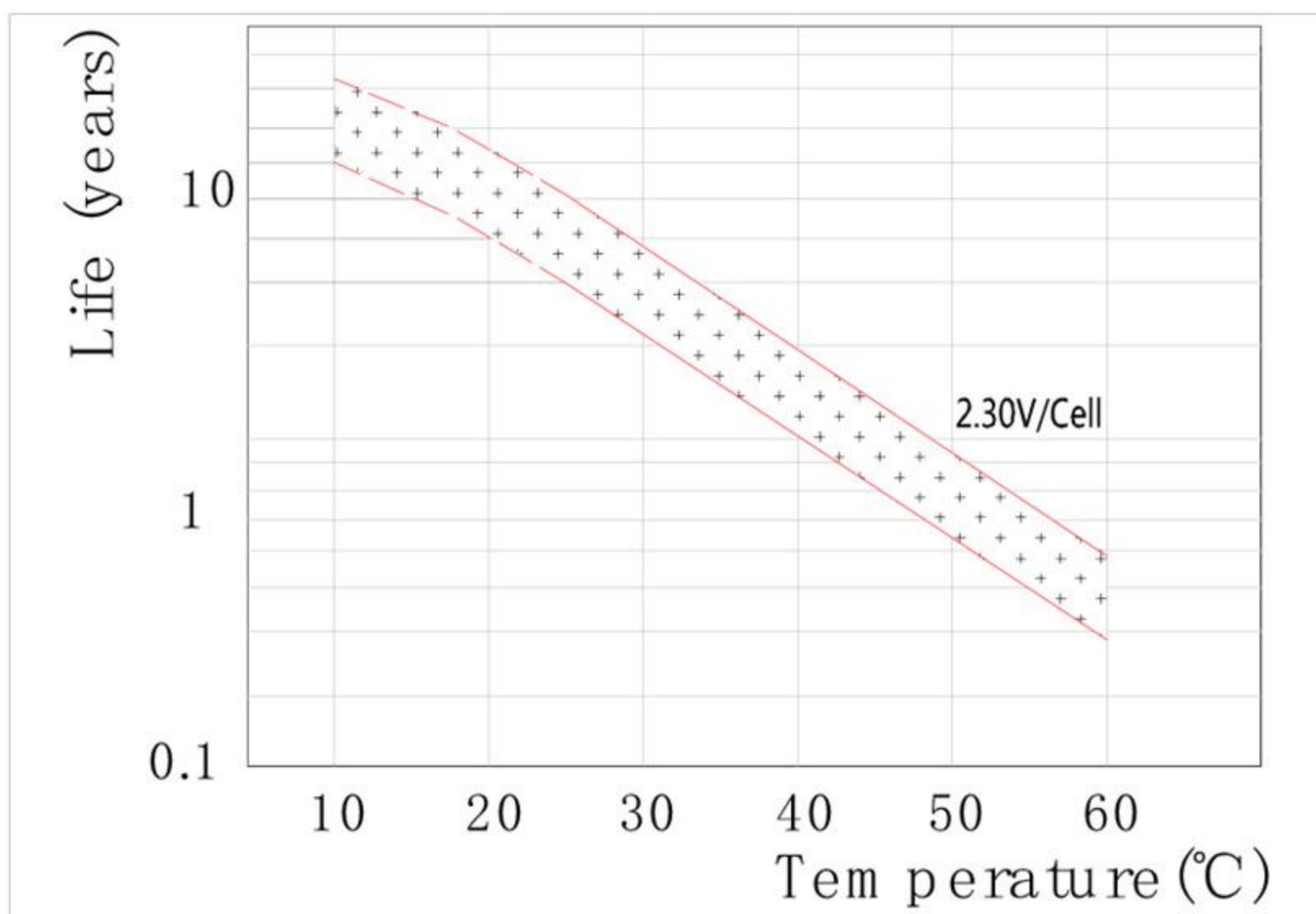

Cycle Life on D.O.D(25°C)

